

MLH Series

All Metal Pressure Sensors



DESCRIPTION

MLH Series pressure sensors combine the latest in Application Specific Integrated Circuit (ASIC) technology with proven media isolated, metal diaphragm design. This digitally compensated sensor offers an unparalleled value and performance combination making it the ideal pressure sensing solution for demanding applications. Fully temperature compensated, calibrated and amplified, the MLH is available in 50 psi to 8,000 psi pressure ranges.

MLH sensors deliver $\pm 0.25\%$ full scale accuracy Best Fit Straight Line (BFSL) and 2% total error over a temperature range of $-40\text{ }^{\circ}\text{C}$ to $125\text{ }^{\circ}\text{C}$ [$-40\text{ }^{\circ}\text{F}$ to $257\text{ }^{\circ}\text{F}$]. Industry standard, field proven connectors and process ports are offered for high reliability and user flexibility.

FEATURES

- All metal wetted parts for use in wide variety of fluid applications
- No internal elastomeric seals mean no o-ring compatibility issues
- Amplified outputs eliminate cost of external amplifiers
- Input reverse voltage and output short circuit protections guard against mis-wiring
- Less than 2 ms response time provides accurate, high speed measurement
- Rated IP65 or better for protection from harsh environments
- Exceeds CE heavy industrial EMC for use in areas of high RFI/EMI

The MLH has seven standard output options:

- A. 0.5 Vdc to 4.5 Vdc ratiometric output from 5 Vdc excitation
- B. 4 mA to 20 mA current from 9.5 Vdc to 30 Vdc excitation
- C. 1.0 Vdc to 6.0 Vdc regulated output from 8 Vdc to 30 Vdc excitation
- D. 0.25 Vdc to 10.25 Vdc regulated output from 14 Vdc to 30 Vdc excitation
- E. 0.5 Vdc to 4.5 Vdc regulated output from 7 Vdc to 30 Vdc excitation
- F. 0 mV to 50 mV from 5 Vdc excitation
- G. 1 Vdc to 5 Vdc output from 8 Vdc to 30 Vdc excitation

TYPICAL APPLICATIONS

- Diesel engines
- Refrigeration and HVAC/R
- General industrial
- General hydraulics
- Off road vehicles
- Braking systems
- Natural gas vehicles

MLH Series

SPECIFICATIONS (All specifications are measured at 25 °C [77 °F] and at rated excitation unless otherwise specified.)

Pressure Ranges (Comparable metric units follow same proof and burst specifications)												
Units (psi)	psiG	psiG	psiG	psiG	psiG	psiS	psiS	psiS	psiS	psiS	psiS	psiS
Pressure	50	100	150	200	250	300	500	1000	2000	3000	5000	8000
Proof pressure	150	300	450	600	750	900	1500	2000	4000	6000	7500	12000
Burst pressure	500	1000	1500	2000	2500	3000	5000	10000	20000	30000	30000	30000

Units (bar)	barG	barG	barG	barS	barS	barS	barS	barS	barS	barS	barS	barS
Pressure	6	10	16	25	40	60	100	160	250	350	500	550
Proof pressure	18	30	48	75	80	120	200	320	500	700	750	825
Burst pressure	60	100	160	250	400	600	1000	1600	2068	2068	2068	2068

Physical	
Material in contact with media	Stainless steel and Haynes 214 alloy (or equivalent) (all wetted materials are equivalent or better than 300 series stainless steel). High corrosion resistant Hastelloy C22 sensor available (contact factory).
Housing material	Black plastic – Amodel AS-4133 HS – PPA
Weight	57.0 g [2.0 oz]

Environmental	
Shock	50 g peak [5 ms], 100 g peak [11 ms]
Vibration	Figure 514.2-5, Curve AK, Table 514.2-V, Random Vibration Test [overall g rms = 20.7 min.]

Electrical							
	Ratiometric (A)	Current (B)	Regulated (C)	Regulated (D)	Regulated (E)	milliVolt (F)	Regulated (G)
Zero output	0.5 Vdc	4.0 mA	1.0 Vdc	0.25 Vdc	0.5 Vdc	0 ±2.5 mV	1.0 Vdc
Full scale output ¹	4.0 Vdc (0.5 to 4.5 Vdc)	16 mA (4 to 20 mA)	5.0 Vdc (1.0 to 6.0 Vdc)	10.0 Vdc (0.25 to 10.25 Vdc)	4.0 Vdc (0.5 to 4.5 Vdc)	50 mV (0 to 50 mV)	4.0 Vdc (1.0 to 5.0 Vdc)
Excitation	5 Vdc ±250 mV (6.0 Vdc max.)	9.5 Vdc to 30.0 Vdc	8.0 Vdc to 30.0 Vdc	14.0 Vdc to 30.0 Vdc	7.0 Vdc to 30.0 Vdc	5.0 Vdc (6.0 Vdc max.)	8.0 Vdc to 30.0 Vdc
Supply current	4.0 mA typical (8 mA max.)	N/A	5.0 mA typical (17 mA max.)	5.0 mA typical (17 mA max.)	5.0 mA typical (17 mA max.)	8.0 mA typical (17 mA max.)	5.0 mA typical (17 mA max.)
Source (nominal)	1.0 mA	N/A	1.0 mA	1.0 mA	1.0 mA	N/A	1.0 mA
Sink (nominal)	1.0 mA @ zero output	N/A	1.0 mA @ zero output	1.0 mA @ zero output	1.0 mA @ zero output	N/A	1.0 mA @ zero output
Supply rejection ratio	90 db	90 db	90 db	90 db	90 db	N/A	90 db
Output impedance	25 Ω max.	N/A	25 Ω max.	25 Ω max.	25 Ω max.	≥2000 Ω	25 Ω max.

Notes: 1. All specifications are measured at 25 °C [77 °F] and at rated excitation unless otherwise specified.

Performance	
Response time	<2 ms
EMI/RFI	<ul style="list-style-type: none"> EC Directive 2004/108/EC (consolidated 89/336) Standard IEC 61326 2002 IEC 61000-4-3-2002 & IEC 61000-4-6 ISO 11452-2 400 MHz to 2 GHz, 100 V/M incl. 1 kHz AM 80% ISO 11452-4 1MHz to 100MHz, 100 mA incl. 1 kHz AM 80%
Accuracy	±0.25 % F.S.O. best fit straight line. Includes: non-linearity, hysteresis, non-repeatability. Thermal errors not included. 0.5 % <100 psi.
Total error band	±2 % FSO includes zero offset error, span error, thermal effect on zero, thermal effect on span, non-linearity, hysteresis and non-repeatability. (±3 % FSO on ranges ≤250 psig.)
Compensated, operating and storage temperature range	-40 °C to 125 °C [-40 °F to 257 °F]

All Metal Pressure Sensors

ORDER GUIDE

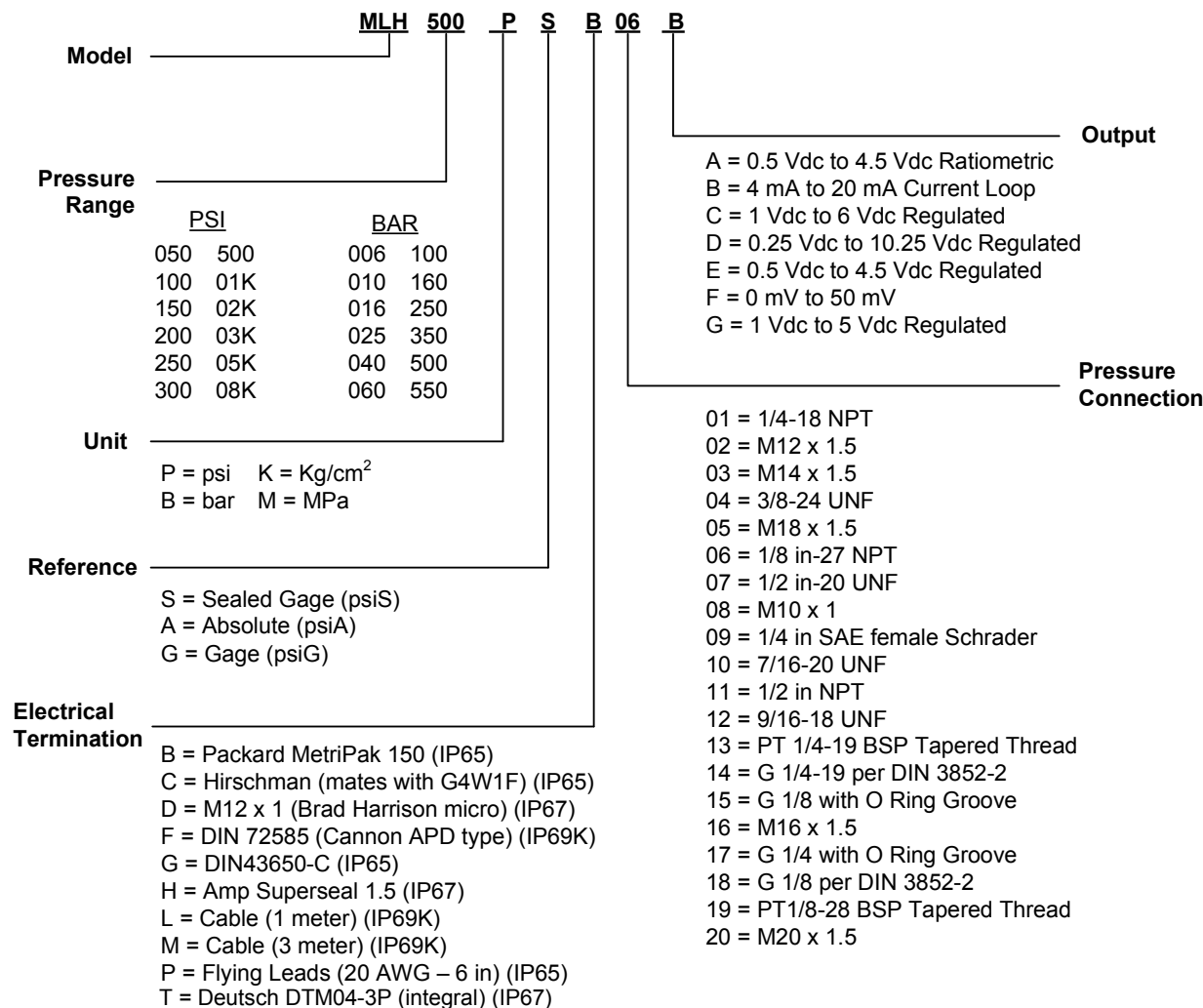

Note: Not all combinations are available. Minimum quantity orders apply. Additional pressure ranges and special calibration versions are available. Contact your local sales representative for assistance.

MOUNTING DIMENSIONS (For reference only. mm/(in).)

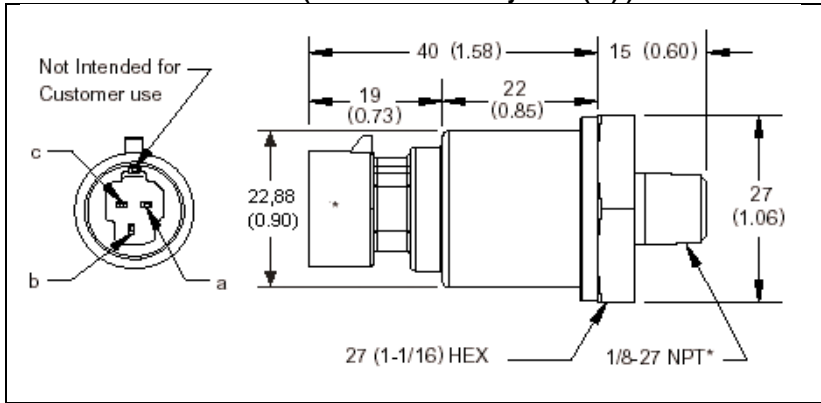

PIN AND WIRE CODES

(Option B – Packard)

Pin	Voltage	Current
a	+ Excitation	+ Excitation
b	Output	- Excitation
c	Common	No Connection

A variety of pressure ports and electrical termination connection options are available. Refer to the “How to Order” on previous page for possible combinations. Contact your Honeywell representative for details.

⚠ WARNING

MISUSE OF DOCUMENTATION

- The information presented in this product sheet is for reference only. Do not use this document as a product installation guide.
- Complete installation, operation, and maintenance information is provided in the instructions supplied with each product.

Failure to comply with these instructions could result in death or serious injury.

⚠ WARNING

PERSONAL INJURY

DO NOT USE these products as safety or emergency stop devices or in any other application where failure of the product could result in personal injury.

Failure to comply with these instructions could result in death or serious injury.

WARRANTY/REMEDY

Honeywell warrants goods of its manufacture as being free of defective materials and faulty workmanship. Honeywell’s standard product warranty applies unless agreed to otherwise by Honeywell in writing; please refer to your order acknowledgement or consult your local sales office for specific warranty details. If warranted goods are returned to Honeywell during the period of coverage, Honeywell will repair or replace, at its option, without charge those items it finds defective. **The foregoing is buyer’s sole remedy and is in lieu of all other warranties, expressed or implied, including those of merchantability and fitness for a particular purpose. In no event shall Honeywell be liable for consequential, special, or indirect damages.**

While we provide application assistance personally, through our literature and the Honeywell web site, it is up to the customer to determine the suitability of the product in the application.

Specifications may change without notice. The information we supply is believed to be accurate and reliable as of this printing. However, we assume no responsibility for its use.

SALES AND SERVICE

Honeywell serves its customers through a worldwide network of sales offices, representatives and distributors. For application assistance, current specifications, pricing or name of the nearest Authorized Distributor, contact your local sales office or:

E-mail: info.sc@honeywell.com

Internet: www.honeywell.com/sensing

Phone and Fax:

- Asia Pacific +65 6355-2828
+65 6445-3033 Fax
- Europe +44 (0) 1698 481481
+44 (0) 1698 481676 Fax
- Latin America +1-305-805-8188
+1-305-883-8257 Fax
- USA/Canada +1-800-537-6945
+1-815-235-6847
+1-815-235-6545 Fax

Automation and Control Solutions

Sensing and Control

Honeywell

1985 Douglas Drive North

Minneapolis, MN 55422

www.honeywell.com/sensing

008118-4-EN IL50 GLO Printed in USA
October 2006

Copyright © 2006. Honeywell International Inc. All rights reserved.

Honeywell