

EFI Hardware
6 Cylinder EFI Air Box
P/N 835-036

Drawing Revision 2 - 8/2/2022



www.youtube.com/efihardware



www.facebook.com/efihardware



www.efihardware.com



info@efihardware.com



(03) 9873 5400
+613 9873 5400



(03) 9873 5955
+613 9873 5955

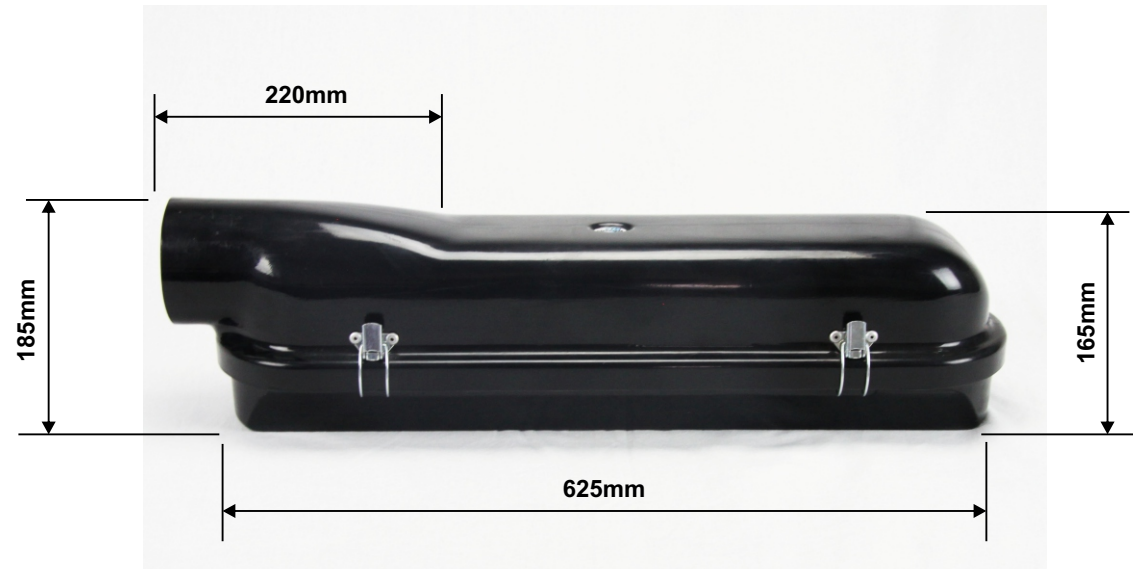
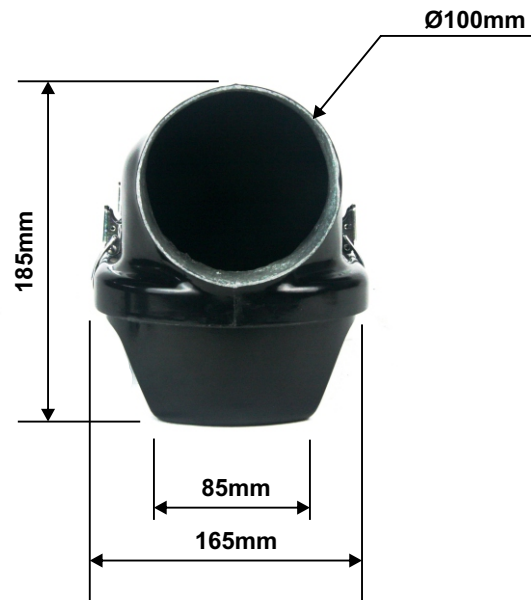

NOTES:

This Air Box is specifically designed for 4 Cylinder Multi Throttled Engines running Electronic Fuel Injection.

The base has a taller V section to allow clearance for your fuel rail in injectors.

Temperature Vs Resistance

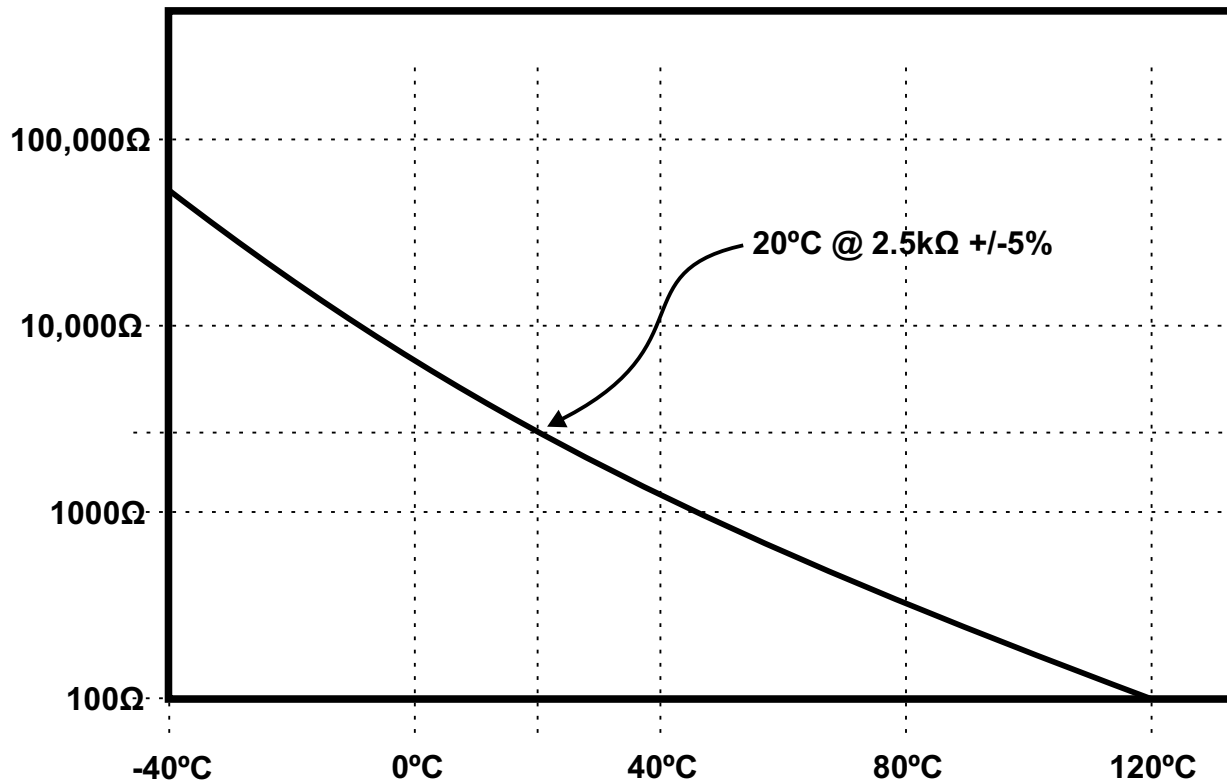

*NOTE: This is an estimate of the voltage as Atmospheric Pressure changes with altitude and weather conditions

NOTES:

This is a passive sensor and requires the use of a pull-up resistor on the signal of this sensor. This pull-up resistor is usually located inside your engine management system.

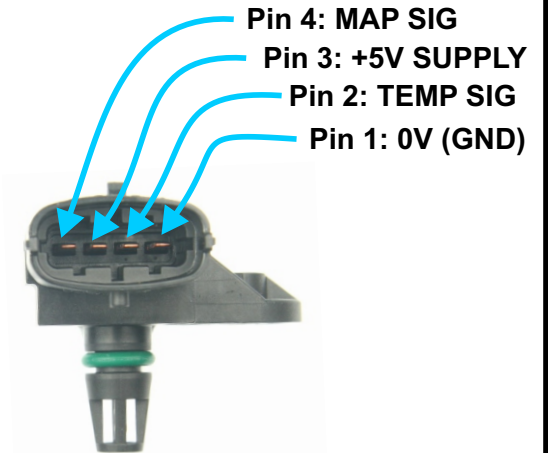

APPLICATIONS:

This sensor is most often used as an intake air temp sensor to monitor engine intake air temperature for an engine management system.