

Fuel Pump FP 200

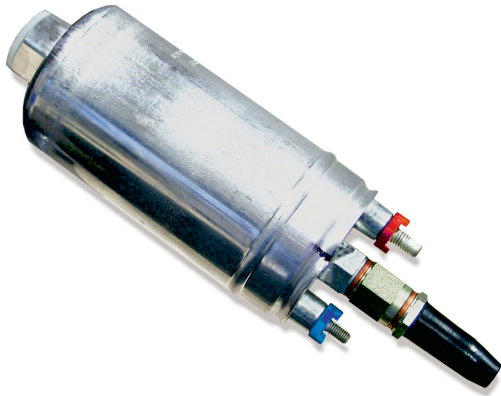

- ▶ >200 l/h
- ▶ Max. 5 bar/8 bar
- ▶ 1,030 g
- ▶ Fuel lines screwed

The FP 200 is an inline roller cell pump for the installation outside or inside the fuel tank. It is capable of providing 200 l/h at 5 bar (8 bar). Bio-fuel can be delivered up to E85 (shortens life-time!). The FP 200 is one of the most popular aftermarket fuel pumps and has an excellent price.

Application

Fuel pressure	5 bar or 8 bar
Delivery rate at 5 bar and 22°C	260 ± 5 l/h at 14 V
Delivery rate at 8 bar and 22°C	220 ± 5 l/h at 14 V
Pressure limiting valve	10 to 12.5 bar rel.
Fuel compatibility	Up to E85 with shorter lifetime
Diesel compatibility	Not released
Operating temperature range	-20 to 90°C
Storage temperature range	-40 to 70°C
Max. vibration	3 mm at 10 to 18 Hz ≤40 m/s ² at 18 to 60 Hz

Technical Specifications

Mechanical Data

Diameter	60 mm
Length	196 mm
Weight	1,030 g
Mounting	Clamping

Electrical Data

Supply voltage	6 to 16.5 V
Operating voltage	13.8 V

Load current at 5 bar and 22°C ≤ 15 A

Load current at 8 bar and 22°C ≤ 18 A

Characteristic

Surface coating	None
Color	Silver
Non-return valve	External
Fuel filtering	External, on pressure side

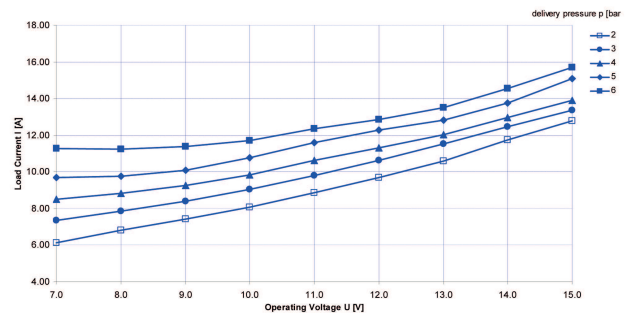
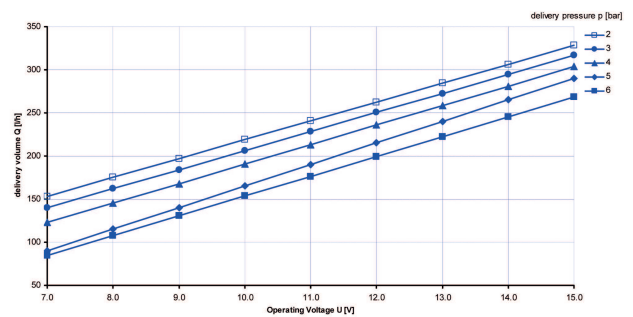

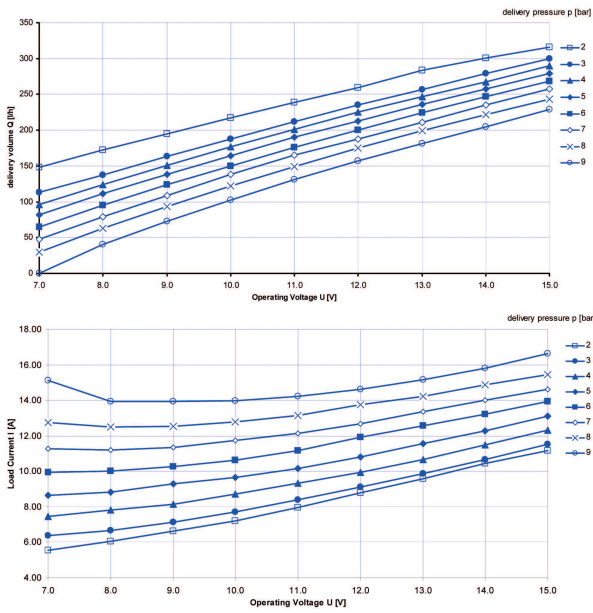

Connectors and Wires

Electrical connector +M6/-M5

Electrical mating connector	With ring wire M6 and M5
Mechanical connector intake side	M18x1.5
Mechanical connector pressure side	M12x1.5

Installation Notes

With E26/E85 fuel run-time max. 500 h.
 For technical reasons the values may vary.
 Please use within the specified limit values only.
 Please find further application hints in the offer drawing at our homepage.

Ordering Information

Fuel Pump FP 200
 Max. Pressure 5 bar
 Order number **0580.254.044**

Fuel Pump FP 200
 Max. Pressure 8 bar
 Order number **B261.205.413-01**

Dimensions

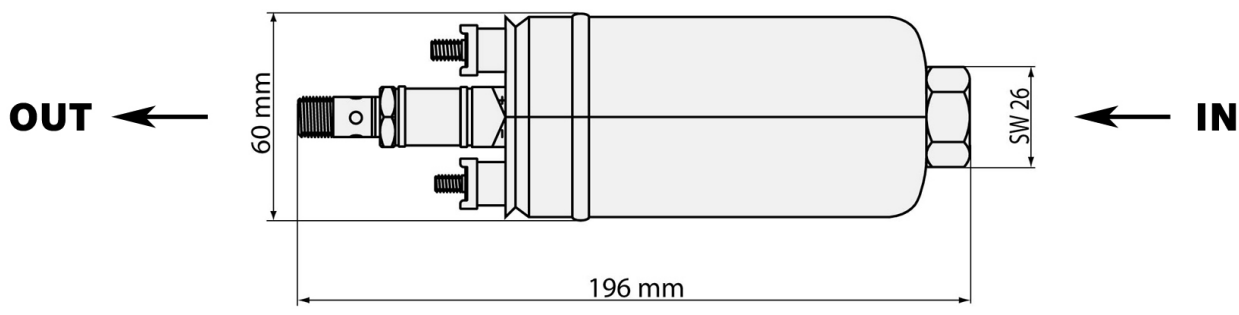

Represented by:

Europe:
 Bosch Engineering GmbH
 Motorsport
 Robert-Bosch-Allee 1
 74232 Abstatt
 Germany
 Tel.: +49 7062 911 9101
 Fax: +49 7062 911 79104
 motorsport@bosch.com
 www.bosch-motorsport.de

North America:
 Bosch Engineering North America
 Motorsport
 38000 Hills Tech Drive
 Farmington Hills, MI 48331-3417
 United States of America
 Tel.: +1 248 876 2977
 Fax: +1 248 876 7373
 motorsport@bosch.com
 www.bosch-motorsport.com

Asia-Pacific:
 Bosch Engineering Japan K.K.
 Motorsport
 18F Queen's Tower C, 2-3-5 Minato
 Mirai Nishi-ku, Yokohama-shi
 Kanagawa 220-6218
 Japan
 Tel.: +81 45 650 5610
 Fax: +81 45 650 5611
 www.bosch-motorsport.jp

Australia, New Zealand and South Africa:
 Robert Bosch Pty. Ltd
 Motorsport
 1555 Centre Road
 Clayton, Victoria, 3168
 Australia
 Tel.: +61 (3) 9541 3901
 motor.sport@au.bosch.com